



Science Operations for SOFIA: The FORCAST Experience

Herter: 10-Aug-11

Experiences flying on SOFIA

- It has been both challenging and rewarding
 - We are part of a making a highly complex system work
 - But, of course, that is the point (to push new boundaries)
- At every stage things have worked better than (I) expected
- Observatory performance is quite good
 - Would like continued image quality improvement
- Great team effort by everyone

Instrument Overview



- ❑ Facility Instrument
- ❑ Dual-Channel 256x256 Camera w/
Si BIB arrays
 - 5-25 μm with Si:As array
 - 25-40 μm with Si:Sb array
- ❑ Field of View
 - 0.75"/pixel giving a 3.2'x3.2'
- ❑ Designed for diffraction-limited imaging for $\lambda > 15 \mu\text{m}$
- ❑ Selectable Filters in 5-40 μm range
- ❑ Can easily accommodate gratings for spectroscopic capability

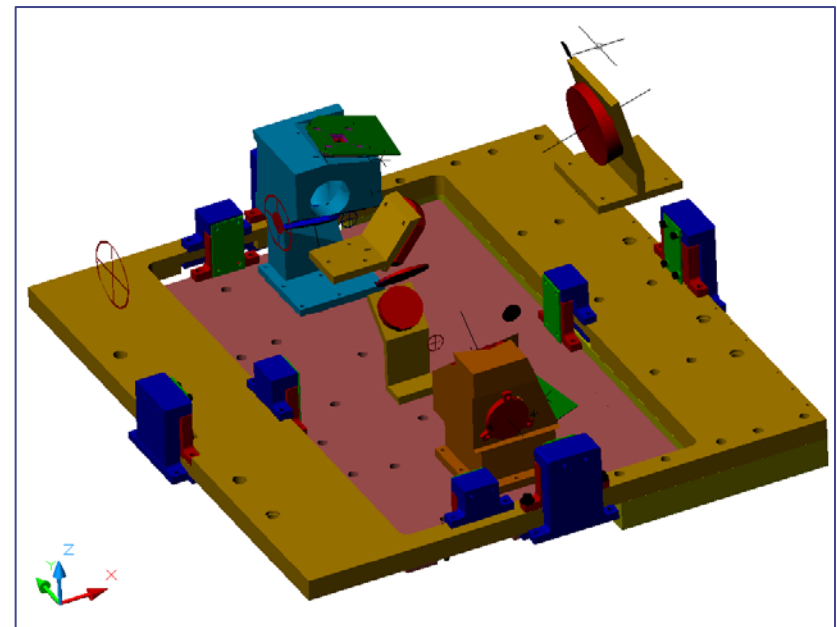
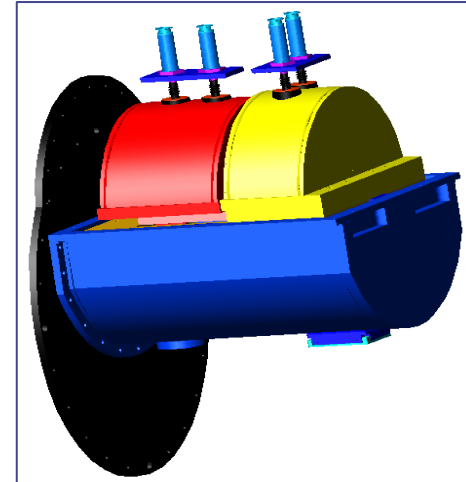

Filters for Basic Science

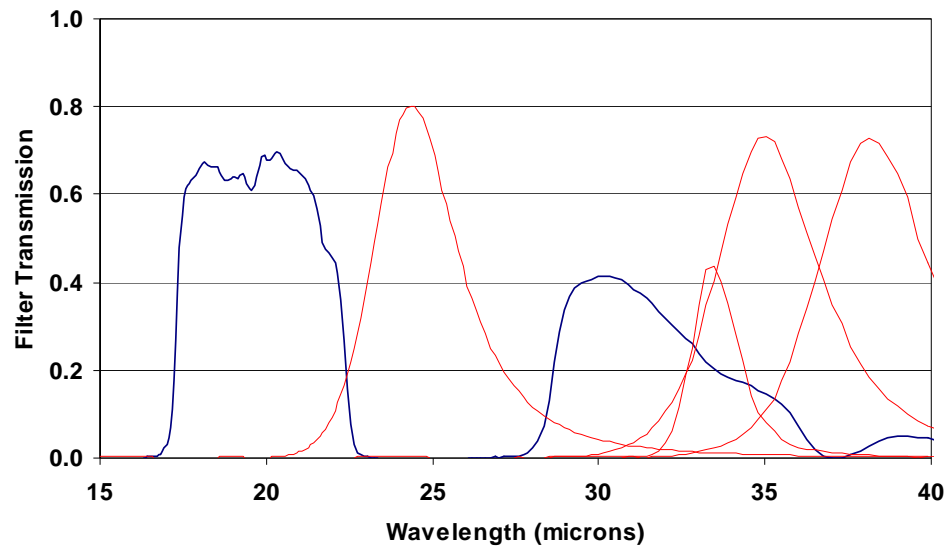
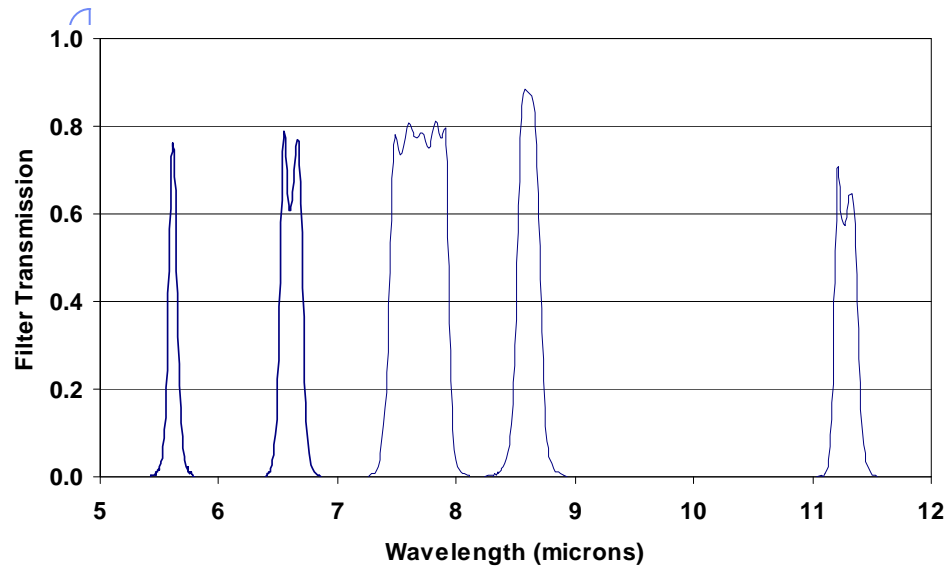

Filter (μm)	R ($\lambda/\Delta\lambda$)
5.3	33
6.3	48
6.6	34
7.6	15
8.6	42
11.0	12
11.28	56
19.5	3.8
24.4	7.5
30.6	5.7
33.4	18
34.8	8.3
37.1	8.8

Left: representative FORCAST filter curves (not including atmospheric transmission or detector response).

The Observing Experience

Preparation and flights consisted of the following:

- LineOps (Line Operations, 19 in total)
 - Park plane on tarmac and look at stars
 - Allowed end-to-end testing of H/W & S/W
 - This provided extremely important practice
- Observatory characterization flights
 - 25-May-2010, 10-Nov-2010, 18-Nov-2010
 - ◆ Observatory operational and performance checkout
 - ◆ High speed “jitter” measurements of bright stars
 - ◆ Also measured primary-secondary telescope emissivity
- Short Science flights
 - 30-Nov-2010, 03-Dec-2010, 07-Dec-2010
 - ◆ Observed Jupiter, Comet Hartley 2, M42, W3, M82 + calibrators
- Basic Science flights (support of guest investigations)
 - 10 flights: 05-May through 07-Jun-2011

FORCAST LineOps PSF Size

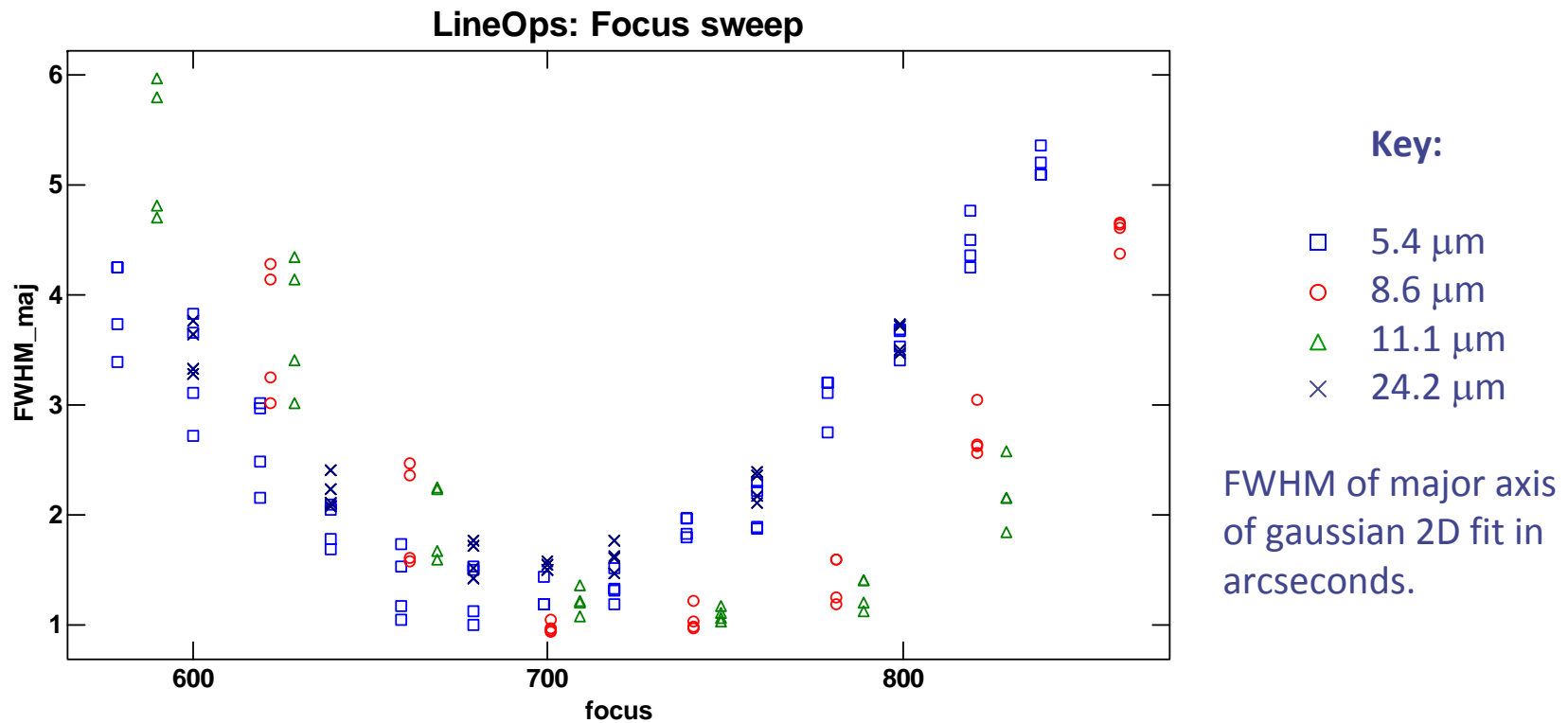

- Focus sequence showing FWHM of star measured during LineOps
 - 24.2 μm filter is actually responding at $\sim 5 \mu\text{m}$ due to light leak and atmospheric transparency.
- FWHM at best focus < 1.4 arcseconds

Line Ops PSF measurements

Source	Lambda (μm)	Focus Major Axis	Focus Minor Axis	FWHM Major (arcsec)	FWHM Minor (arcsec)	T_exp (sec)	Files
RX Boo	11.1	745	740	1.5	1.1	5	54-60
	19.7	735	735	2.0	1.8	30	47-53
Alpha Boo	5.4	695	690	1.3	1.0	5	22-35
	8.6	735	725	0.9	0.7	5	15-21
	11.1	745	745	1.1	0.8	5	8-14

Observations made with SOFIA parked on tarmac at Dryden Airborne Operations Facility (DAOF) in Palmdale.

Basic Science Configuration

- ❑ Chop configuration
 - Two position chop with nodding
- ❑ Observing Modes
 - Symmetric chop
 - ◆ Chop symmetrically about nominal optical axis
 - “Asymmetric” chop
 - ◆ Area of interest observed on-axis
 - ◆ Maintains image quality
 - ◆ Only 1 in 4 frames contain the source
- ❑ Channel Readout
 - SWC, LWC, or both
 - Performance penalty for LWC when both are read simultaneously.

Primary-Secondary Emissivity

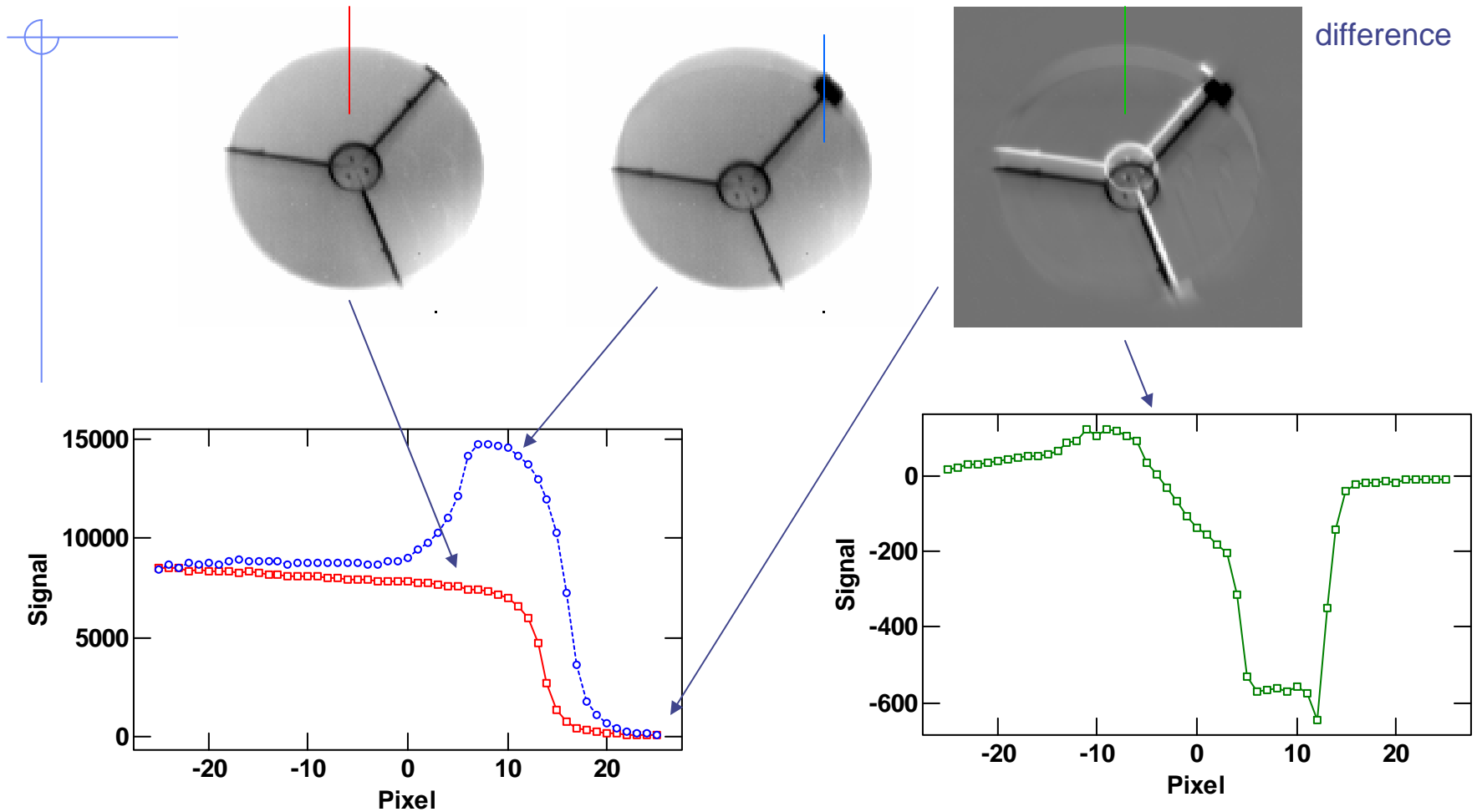

- bLE01_0039-41.fits, FR = 102 Hz, 11.3 μm
- Coll_LL = 539/639
- $S_{\text{blk}} = 14700$, $S_{\text{on}} = 6580$, $\Delta S_{\text{off}} = 570$

$$\varepsilon_{ps} = \frac{S_{\text{on}} - S_{\text{off}}}{S_{\text{blk}} - S_{\text{off}}} = \frac{570}{8690} = 6.6\%$$

Telescope Temperature vs. time

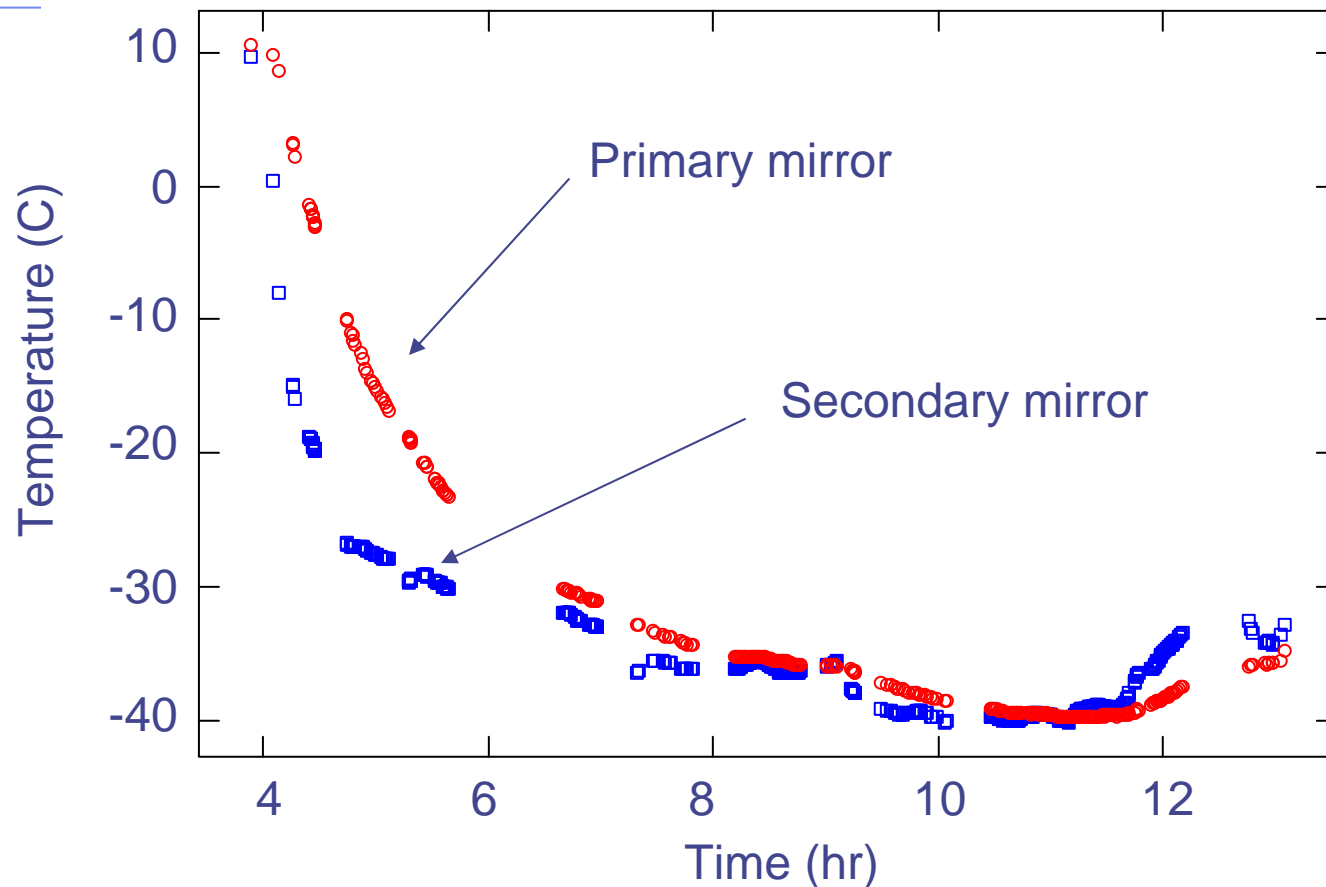

- TA primary (red) and secondary (blue) temperatures vs. UT for short science flight #1

Telescope Temperature vs. time

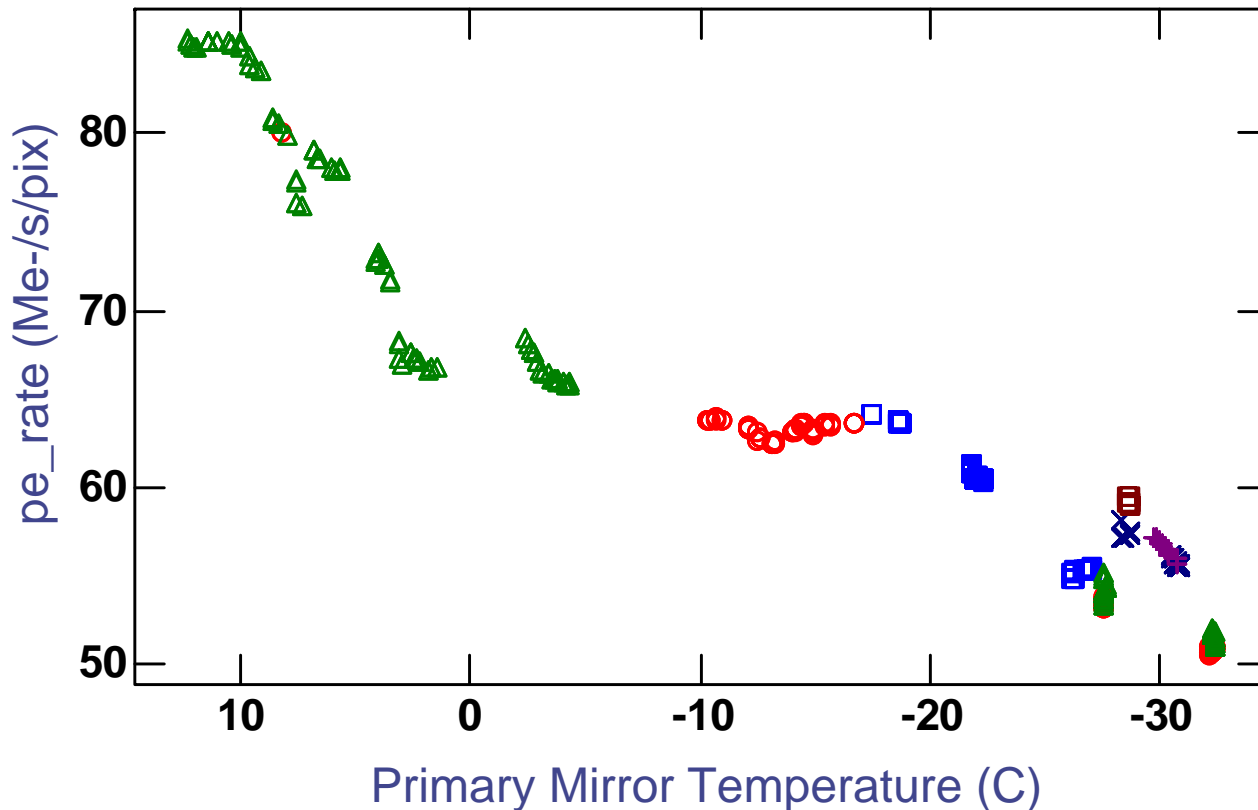

PSF comparisons

Short term

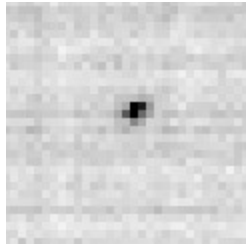

align & add

Long term

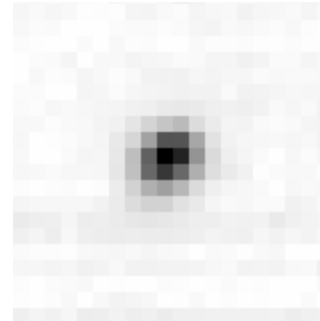

straight addition

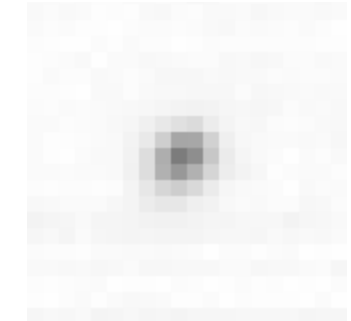

Scale same as short term

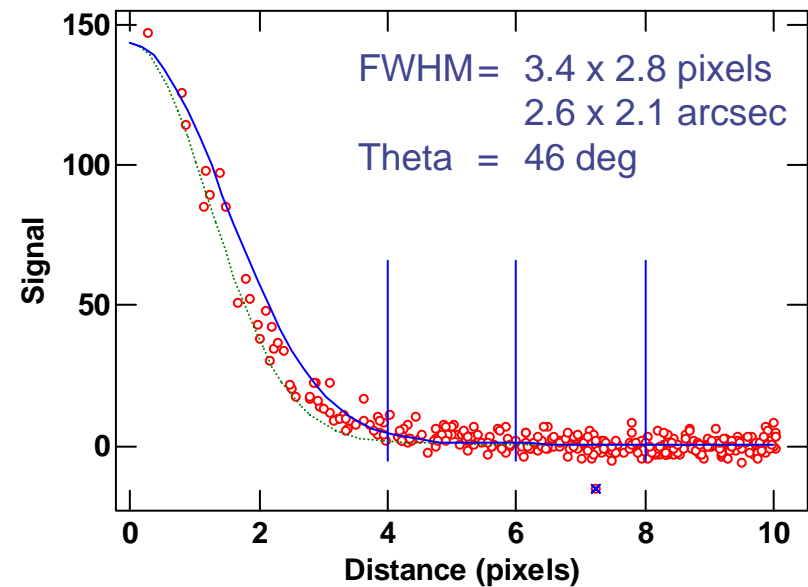
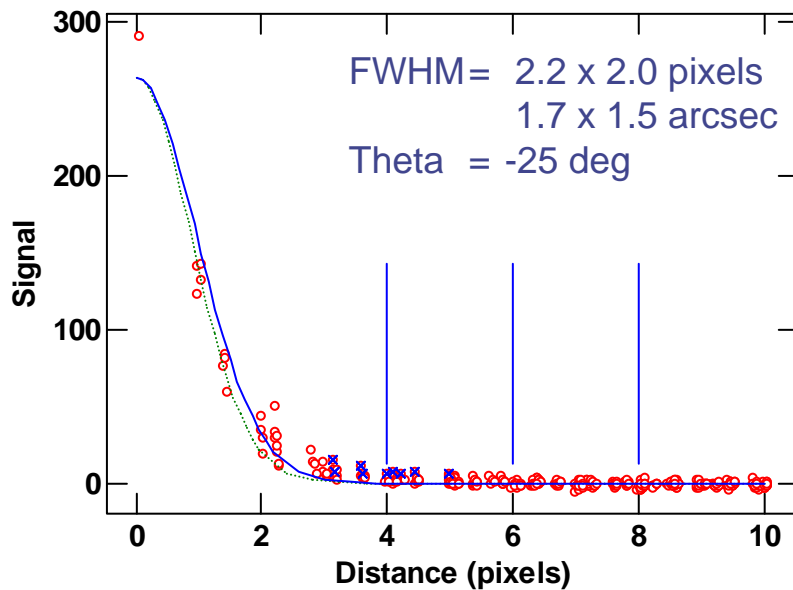

From 500 Hz sampling at 11.1 μm , coadded 2500 exposures, from OCF#3

Image Quality – OCF#3

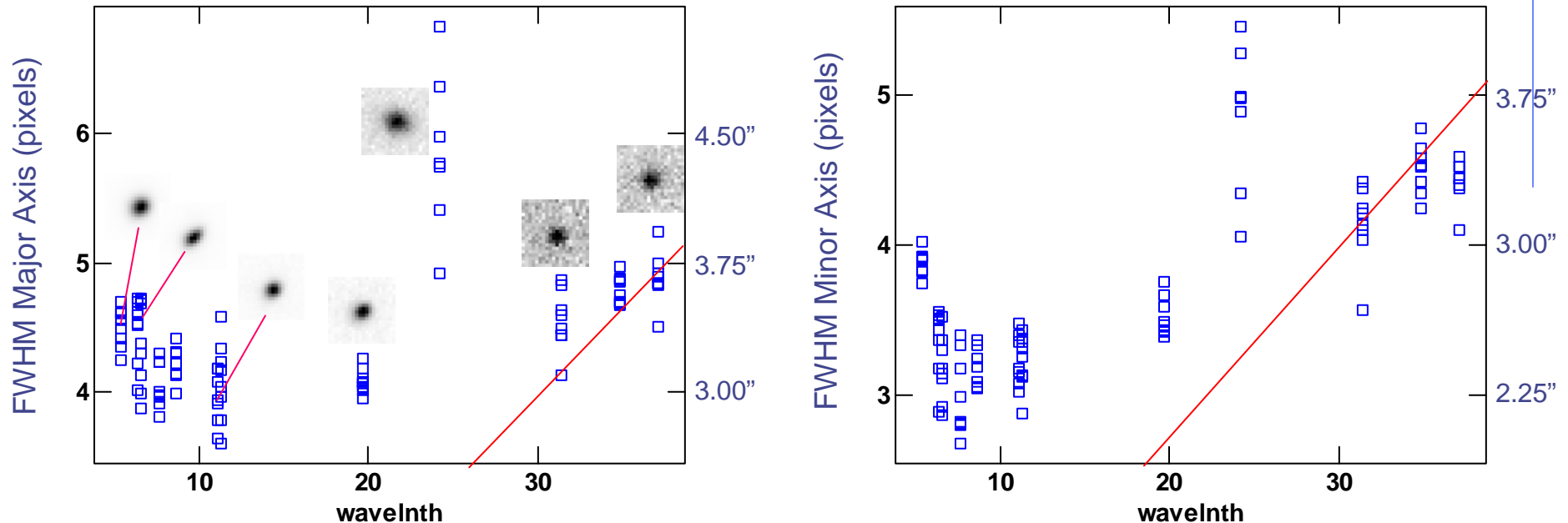

- FWHM of PSF major axis vs wavelength from OCF #3 at altitude ~ 43k feet from Beta And. Pixels are 0.75 arcseconds. Exposure time = 5 seconds, except for 34.8 & 37.1 μm which is 30 seconds. Red line is diffraction limit.

Image Quality – SS#3

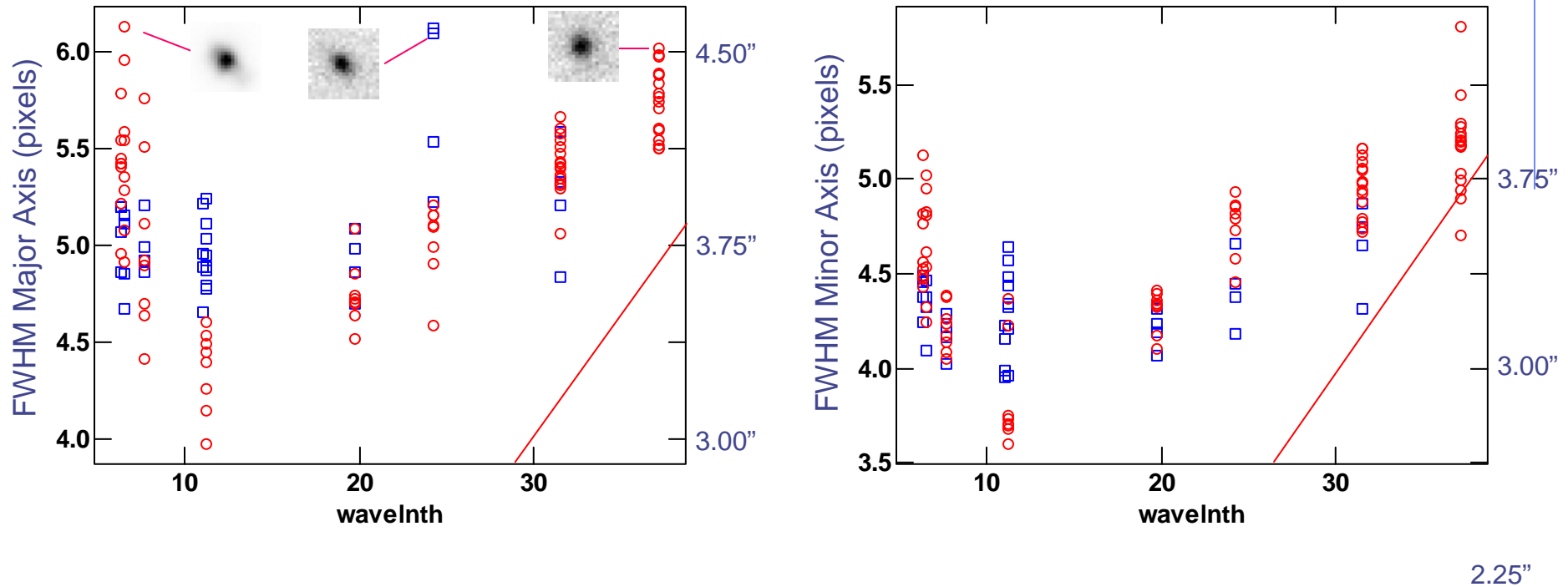

- FWHM of PSF vs. wavelength for SS#3 for mu Ceph (red, at 41k) and Sirius (blue, at 43k). Pixels are 0.75 arcseconds. Exposure time is 5 seconds for mu Ceph and 10-30 seconds for Sirius. Red line is diffraction limit.

FORCAST Science Observations

- Short Science sample images
 - Orion and W3
- Basic Science sample images
 - Pistol/Sickle region of Galactic Center
 - Circumnuclear disk around Sgr A*
- But first
 - A word on calibration ...

Calibrator consistency

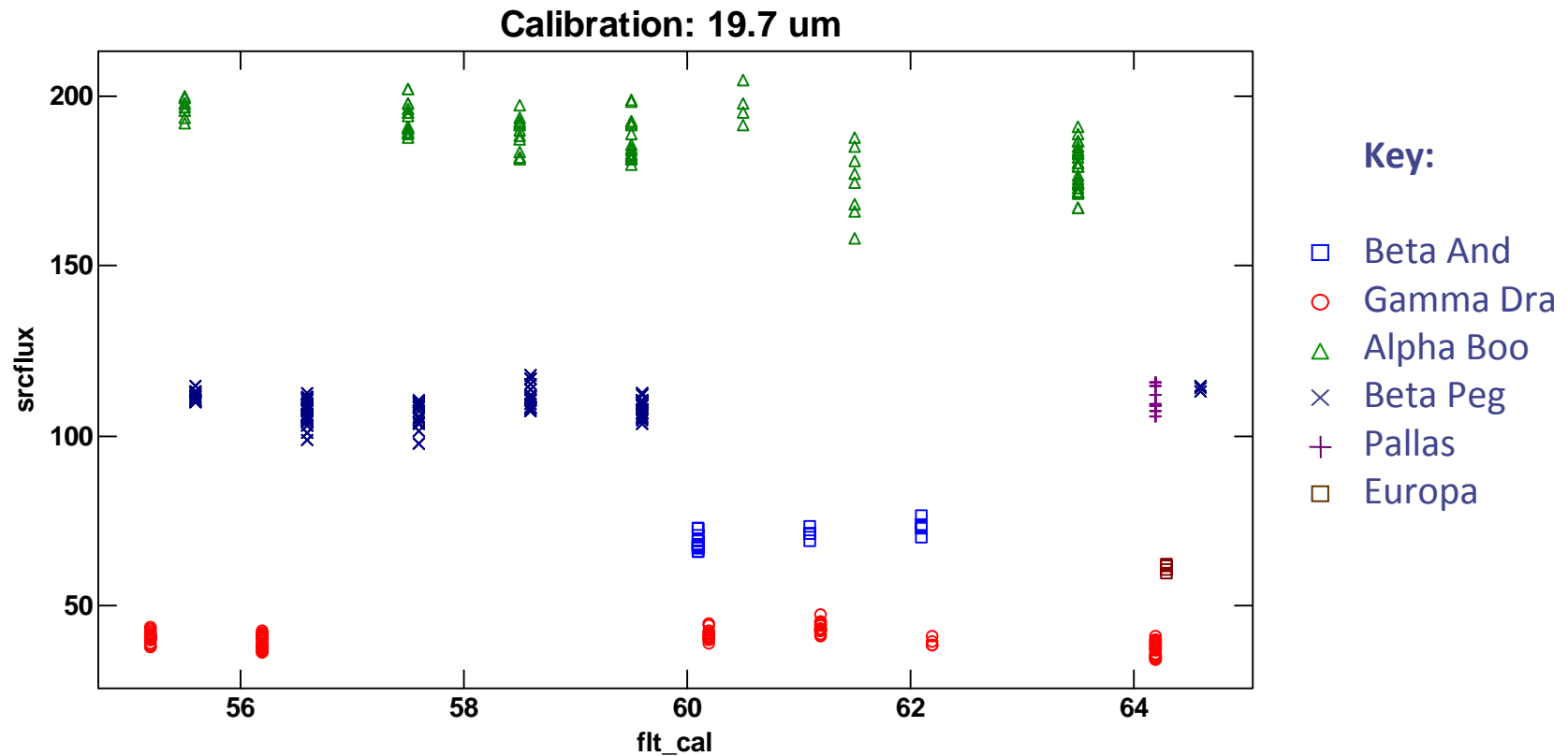

- Calibrator flux at 19.7 microns derived from “standard” (preliminary) calibration for Basic Science flights (numbered as SOFIA flights 55 – 64)

Calibrator consistency

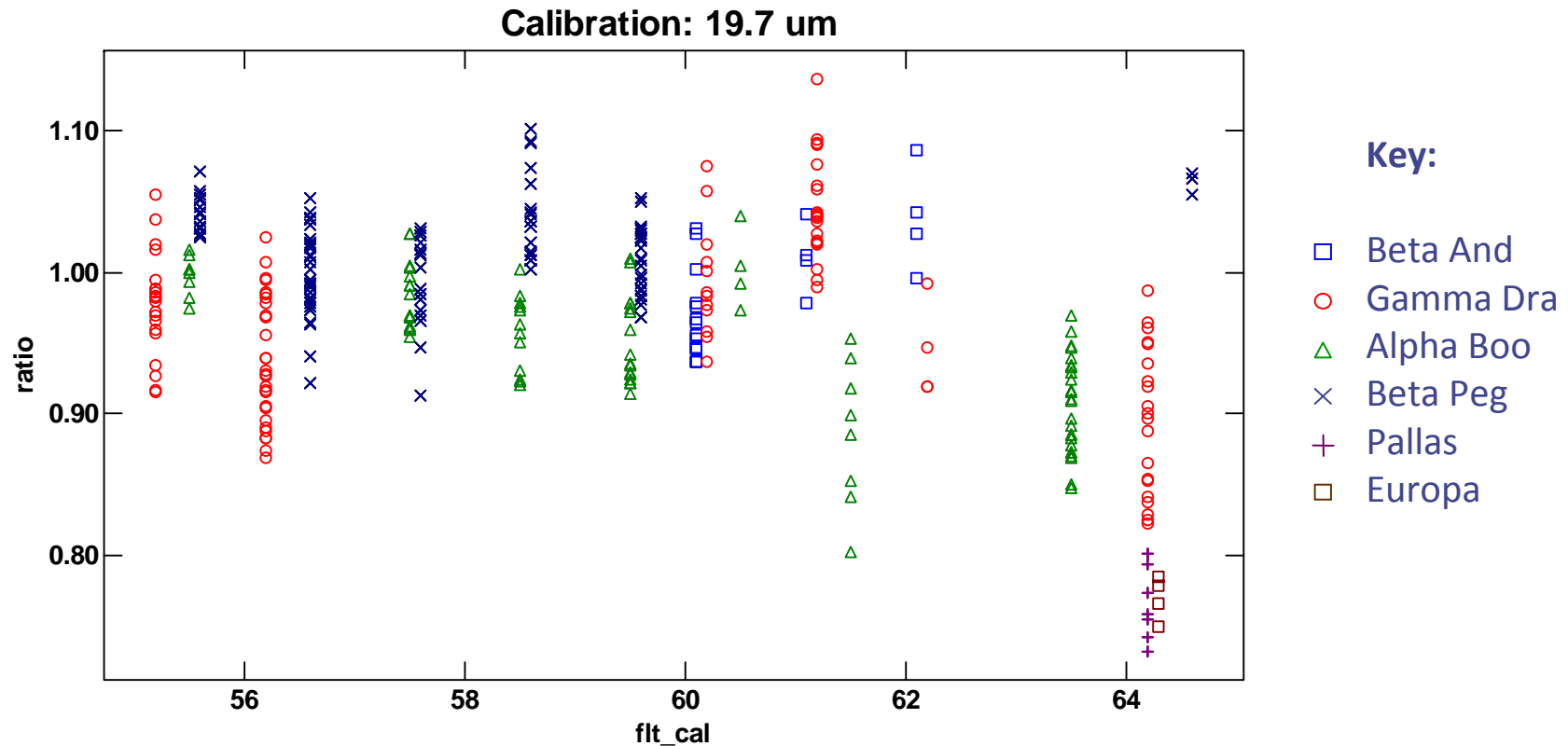

- Ratio of calibrator flux derived from “standard” (preliminary) calibration relative to “actual” flux at 19.7 microns for Basic Science flights
- When flight based correction corrections applied should be better than 20% and likely better than 10% (rms).

SOFIA: Orion Image

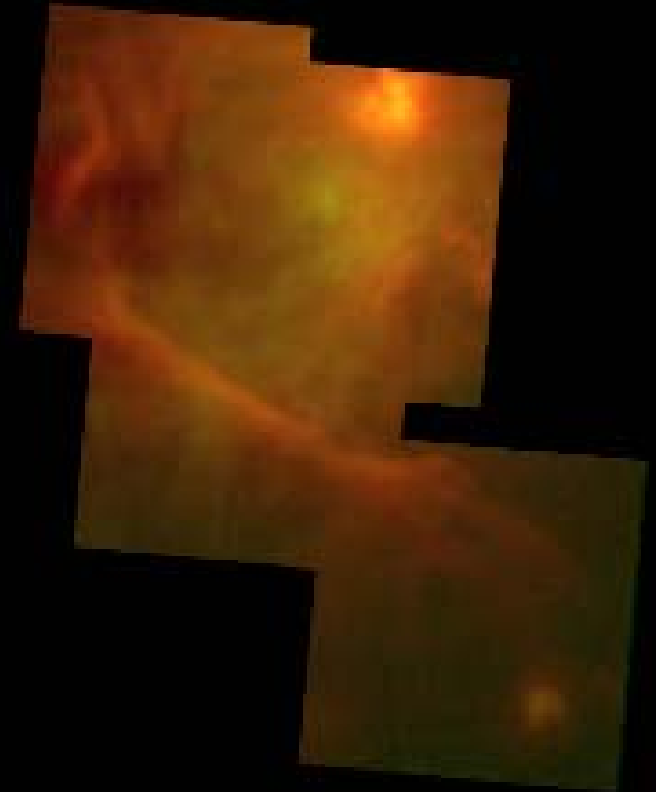

- ❑ Left: Visible (HST, O'Dell and Wong),
- ❑ Middle: Near-IR (McCaughrean),
- ❑ Right: SOFIA 19.7 μm (green) + 37 μm (red) image

Filters for Basic Science

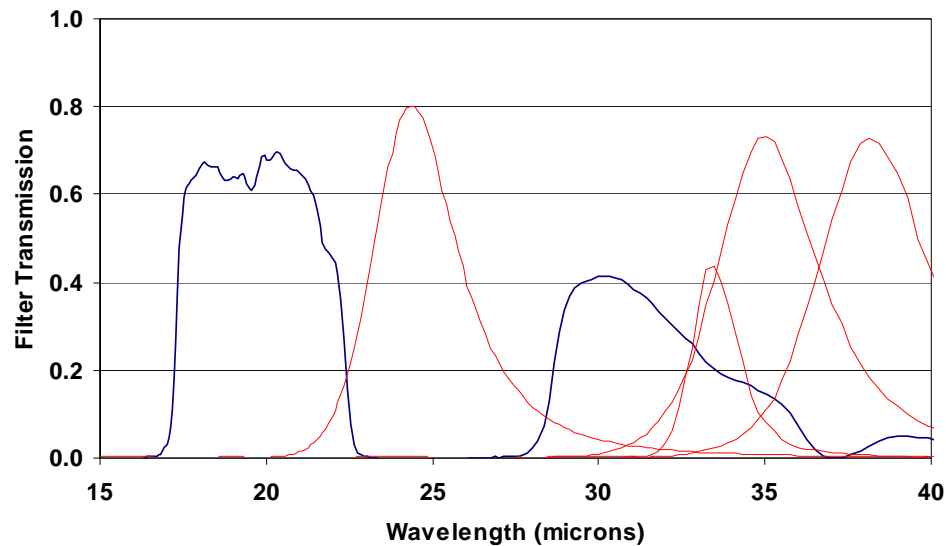
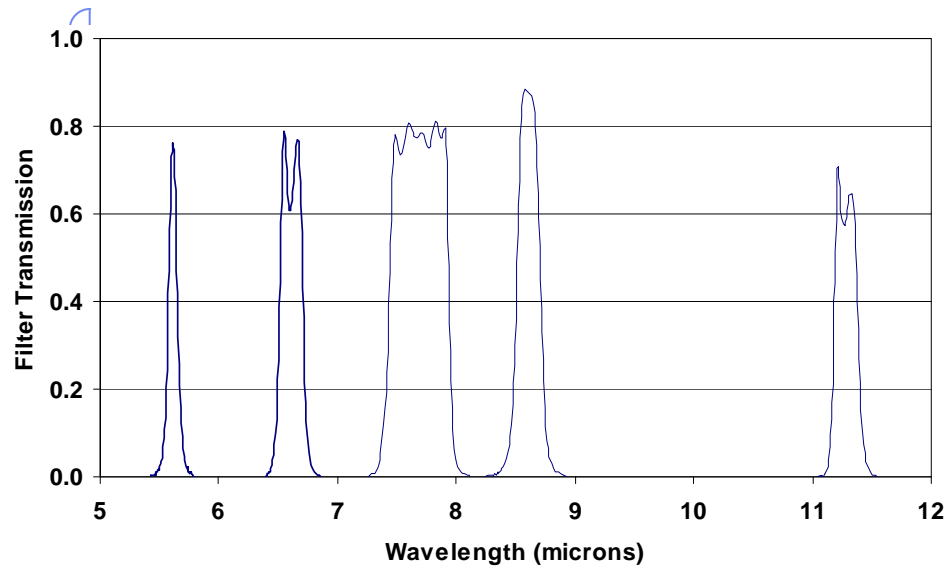

Filter (μm)	R ($\lambda/\Delta\lambda$)
5.3	33
6.3	48
6.6	34
7.6	15
8.6	42
11.0	12
11.28	56
19.5	3.8
24.4	7.5
30.6	5.7
33.4	18
34.8	8.3
37.1	8.8

Left: representative FORCAST filter curves (not including atmospheric transmission or detector response).

FORCAST Response

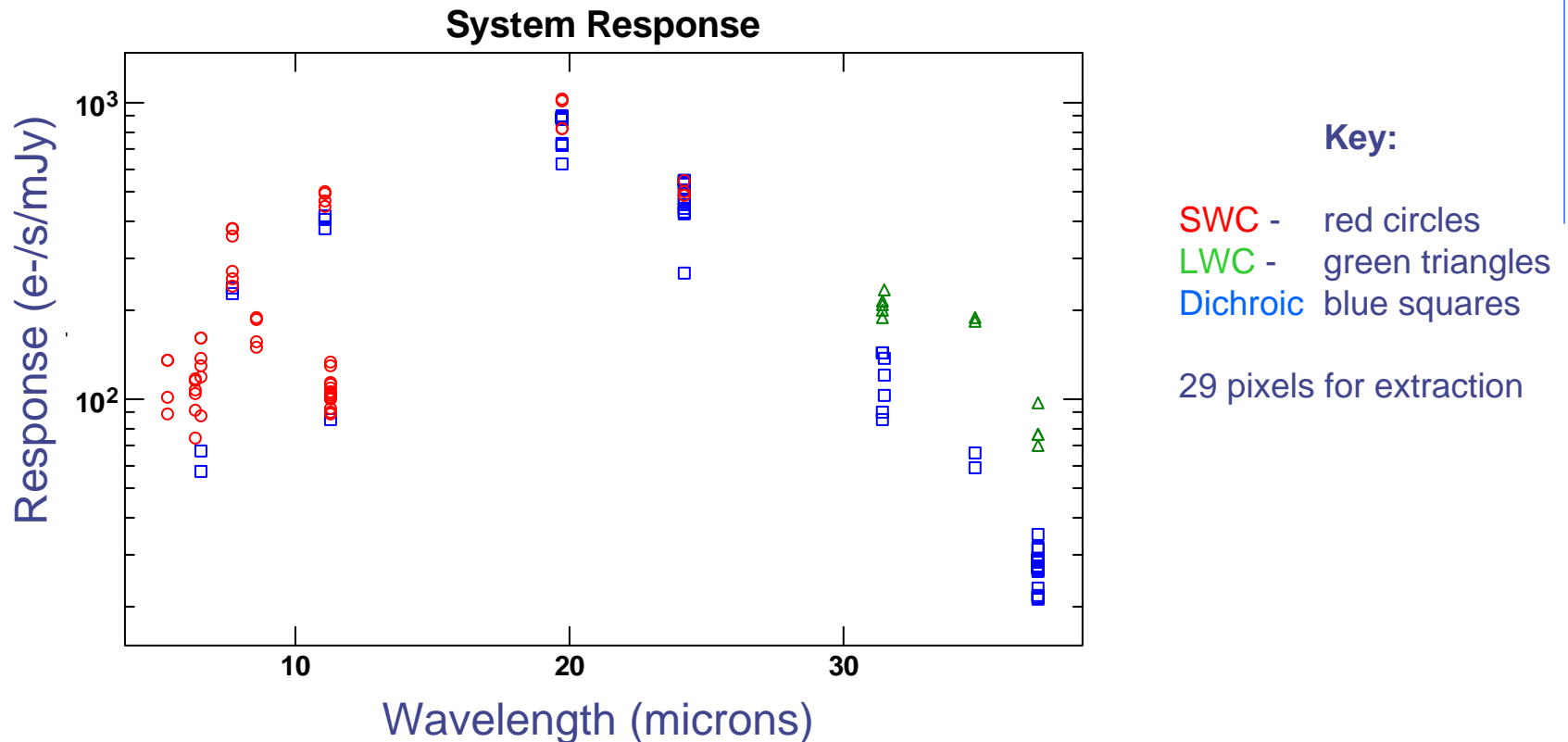

- FORCAST spectral response from OCF#3 and short science calibration data.
- Variability is due to altitude, elevation, and presence of dichroic.

FORCAST Sensitivity

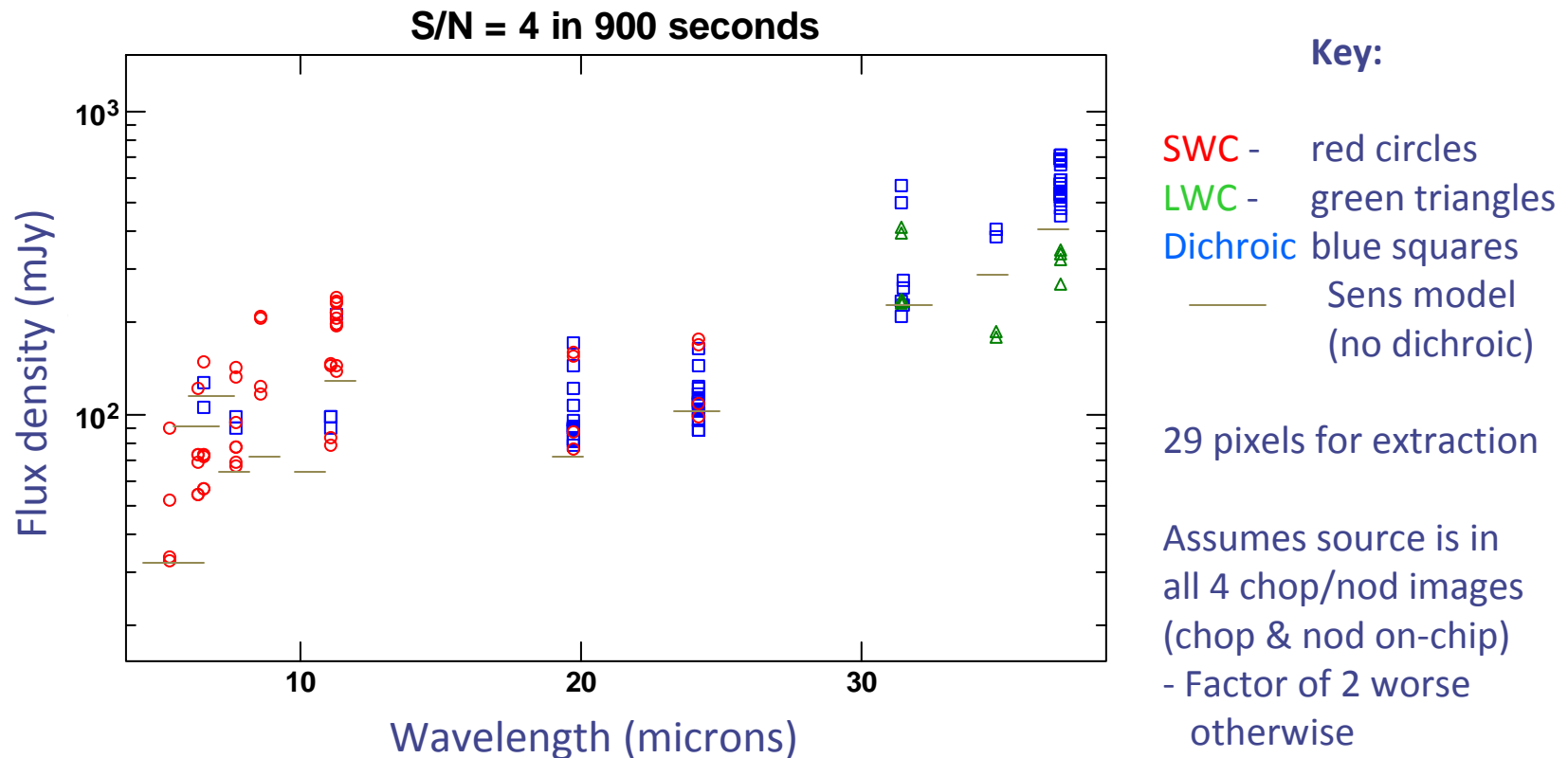

- Estimated flux density of a point source for signal-to-noise ratio of 4 in 900 seconds based on calibrator images from OCF#3 and short science flights.
- Variability is due to altitude, elevation, and presence of dichroic.

Summary

- Science flights have been highly successful.
 - 3 Short Science and 10 Basic Science have lots of publishable results
- Science breadth
 - Wide range of programs covering planetary science, star formation, stellar evolution, the interstellar medium, and others.
- FORCAST niche will be
 - Spatial resolution & wavelength coverage
 - Grisms spectroscopy (to be commissioned next year)